

Lipped Wedge Anchors BZP - ETA Approved





Characteristics

- Functioning by deformation.
- European approval for structural applications in non-cracked concrete.
- European approval for non-structural applications in cracked and non-cracked concrete.
- Installation prior to the material to be fixed.
- Version for fastening diamond cutting equipment.
- Bolt can be disassembled so that the surface of the base material is smooth. Bolt not included.
- VdS available for sizes from M8 to M20.
- FM available for sizes from M10 to M16.

Application

- Fixing suspended ceilings, sprinklers and ventilation systems.
- Structural fixing, inner and outer ironworks.
- Fixing threaded bar.
- Fixing in hollow core slabs.

Range

Code	Sizes	Photo	Component	Material	Covering
B313-470	M6 to M16		Capsule cone	Carbon steel, zinc plated coating ≥ 5 µm	
B313-725					
B313-355					
B313-455	M8 to M12				
B313-675					

Size range

M6 - M20

Drill condition



Base material



Assessments



Installation data in concrete

Installation drawing

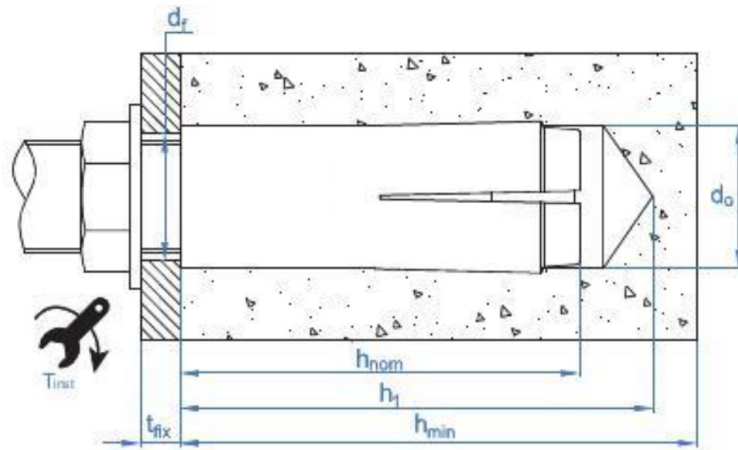

Structural application

Product	Size	ETA Approved	Drill bit diameter	Fixture clearance hole	Maximum torque	Minimum allowable spacing	Minimum allowable edge distance	Minimum concrete thickness	Depth of drill hole	Installation depth	Bolt length*	Critical spacing	Critical edge distance	Installation tool
			d ₀	d _f	T _{inst}	S _{min}	C _{min}	h _{min}	h ₁	h _{nom}	e	Scr,N	Ccr,N	
B313-470	M10 x 40 Ø12	✓	12	12	17	80	140	100	43	40	10 - 17	120	60	B322-500
B313-725	M12 x 50 Ø15	✓	15	14	38	100	175	100	54	50	12 - 21	150	75	B322-600

(*) Bolt length to be threaded(not included) = e + washer thickness + thickness of material to be fixed

Non structural application

Product	Size	ETA Approved	Drill bit diameter	Fixture clearance hole	Maximum torque	Minimum allowable spacing	Minimum allowable edge distance	Minimum concrete thickness	Depth of drill hole	Installation depth	Bolt length*	Critical spacing	Critical edge distance	Installation tool
			d0	df	Tins	Smin	Cmin	hmin	h1	hnom	e	Scr,N	Ccr,N	
B313-470	M10 x 40 Ø12	✓	12	12	17	80	140	100	43	40	10 - 17	120	60	B322-500
B313-725	M12 x 50 Ø15	✓	15	14	38	100	175	100	54	50	12 - 21	150	75	B322-600
B313-355	M8 x 25 Ø10	✓	10	9	11	75	60	80	28	25	8 - 13	120	60	B322-400
B313-455	M10 x 25 Ø12	✓	12	12	17	75	60	80	28	25	10 - 17	120	60	B322-550
B313-675	M12 x 25 Ø15	✓	15	14	38	75	60	80	29	25	12 - 21	120	60	B322-650

(*) Bolt length to be threaded(not included) = e + washer thickness + thickness of material to be fixed

Installation data in hollow core

Installation drawing

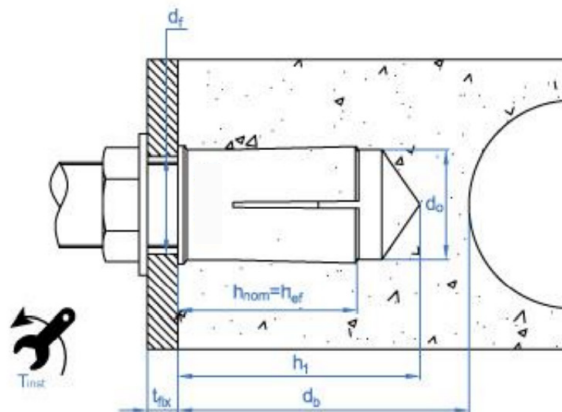

Non structural application

Product	Size	ETA Approved	Drill bit diameter	Fixture clearance hole	Maximum torque	Minimum allowable spacing	Minimum allowable edge distance	Minimum bottom flange thickness	Depth of drill hole	Installation depth	Bolt length*	Critical spacing	Critical edge distance	Installation tool
			d ₀	d _f	T _{ins}	S _{min}	C _{min}	d _b	h ₁	h _{nom}	e	Scr,N	Ccr,N	
B313-355	M8 x 25 Ø10	✓	10	9	11	200	150	35	28	25	8 - 13	200	150	B322-400
B313-455	M10 x 25 Ø12	✓	12	12	17	200	150	35	28	25	10 - 17	200	150	B322-550
B313-675	M12 x 25 Ø15	✓	15	14	38	200	150	35	29	25	12 - 21	200	150	B322-650

(* Bolt length to be threaded (not included) = e + washer thickness + thickness of material to be fixed

Installation procedure

Concrete installation

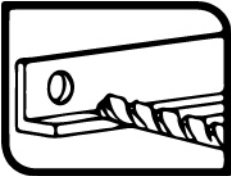
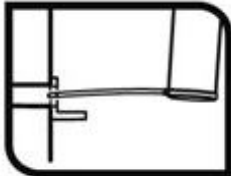
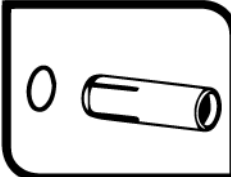
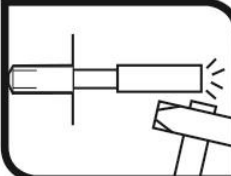
	<p>1. Drill</p> <p>Check the concrete base is well compacted and porosity insignificant. Dry and wet drills allowed. Drill at hammer or percussion position. Respect specified diameter and depth.</p>
	<p>2. Blow and clean</p> <p>Clean hole of dust and debris. Use blow-pump and cleaning brushes.</p>
	<p>3. Installation</p> <p>Introduce the anchor in the hole completely. Use hammer if necessary. The anchor must not stand out of the surface of the base material.</p>
	<p>4. Expand the anchor</p> <p>Insert the expansion tool into the inner cone of the anchor. Hammer until the setting tool is level with the anchor.</p>

Resistance in concrete

Resistances in concrete class C20/25 for an isolated anchor without spacing or concrete edge distance effects are indicated in the following table:

Characteristic resistance [kN]						
General parameters			Structural applications		Non structural application	
Product	Size	ETA Approved	Tension	Shear	ETA Approved	Resistance to any direction
			NRK	VRK		FRK
B313-470	M10 x 40 Ø12	✓	12,45	<u>9,10</u>	✓	5,00
B313-725	M12 x 50 Ø15	✓	17,39	17,39	✓	7,50
B313-355	M8 x 25 Ø10	-	-	-	✓	2,5
B313-455	M10 x 25 Ø12	-	-	-	✓	4,00
B313-675	M12 x 25 Ø15	-	-	-	✓	4,00

1 kN ≈ 100 kg
Values underlined show Steel failure and bold values concrete failure.

Design resistance [kN]						
General parameters			Structural applications		Non structural application	
Product	Size	ETA Approved	Tension	Shear	ETA Approved	Resistance to any direction
			NRK	VRK		FRK
B313-470	M10 x 40 Ø12	✓	5,93	<u>7,28</u>	✓	2,38
B313-725	M12 x 50 Ø15	✓	8,28	11,60	✓	3,57
B313-355	M8 x 25 Ø10	-	-	-	✓	1,39
B313-455	M10 x 25 Ø12	-	-	-	✓	2,22
B313-675	M12 x 25 Ø15	-	-	-	✓	2,22

1 kN ≈ 100 kg
Values underlined show Steel failure and bold values concrete failure.

Maximum loads recommended [kN]						
General parameters			Structural applications		Non structural application	
Product	Size	ETA assessed	Tension	Shear	ETA assessed	Resistance to any direction
			N _{RK}	V _{RK}		F _{RK}
B313-470	M10 x 40 Ø12	✓	4,23	<u>5,20</u>	✓	1,70
B313-725	M12 x 50 Ø15	✓	5,92	8,28	✓	2,55
B313-355	M8 x 25 Ø10	-	-	-	✓	0,99
B313-455	M10 x 25 Ø12	-	-	-	✓	1,59
B313-675	M12 x 25 Ø15	-	-	-	✓	1,59

1 kN ≈ 100 kg
Values underlined show Steel failure and **bold** values concrete failure.

Resistances					
General parameters			Load in all directions [FRk] (Non-Structural applications)		
Product	Size	ETA assessed	Characteristics [kN]	Design [kN]	Maximum recommended load [kN]
B313-355	M8 x 25 Ø10	✓	5,5	3,06	2,18
B313-455	M10 x 25 Ø12	✓	6,0	2,86	2,04
B313-675	M12 x 25 Ø15	✓	6,5	3,10	2,21

1 kN ≈ 100 kg

Resistance in hollow core slabs from C30/37 to C50/60 for an isolated anchor without spacing or concrete edge distance effects are indicated in the table above.

Official documentation

- European assessment ETA 14/0135 for Installation in non-cracked concrete according to guideline EAD 330232-00-0601, option 7, from M6 to M20.
- European assessment ETA 14/0068 for non-structural applications in redundant systems in cracked and uncracked concrete according to guideline EAD 330747-00-0601, option 7, from M6 to M20.
- Declaration of performance DoP HE.
Certificate VdS CEA 4001:2021-01(07) Guidelines for sprinklers systems. Planning and installation for applications of water extinguishing systems on concrete elements from M8 to M20.
- Certificate FM Pipe Hanger Components for Automatic Sprinkler Systems from M10 to M16.